

**PLAN VIEW**

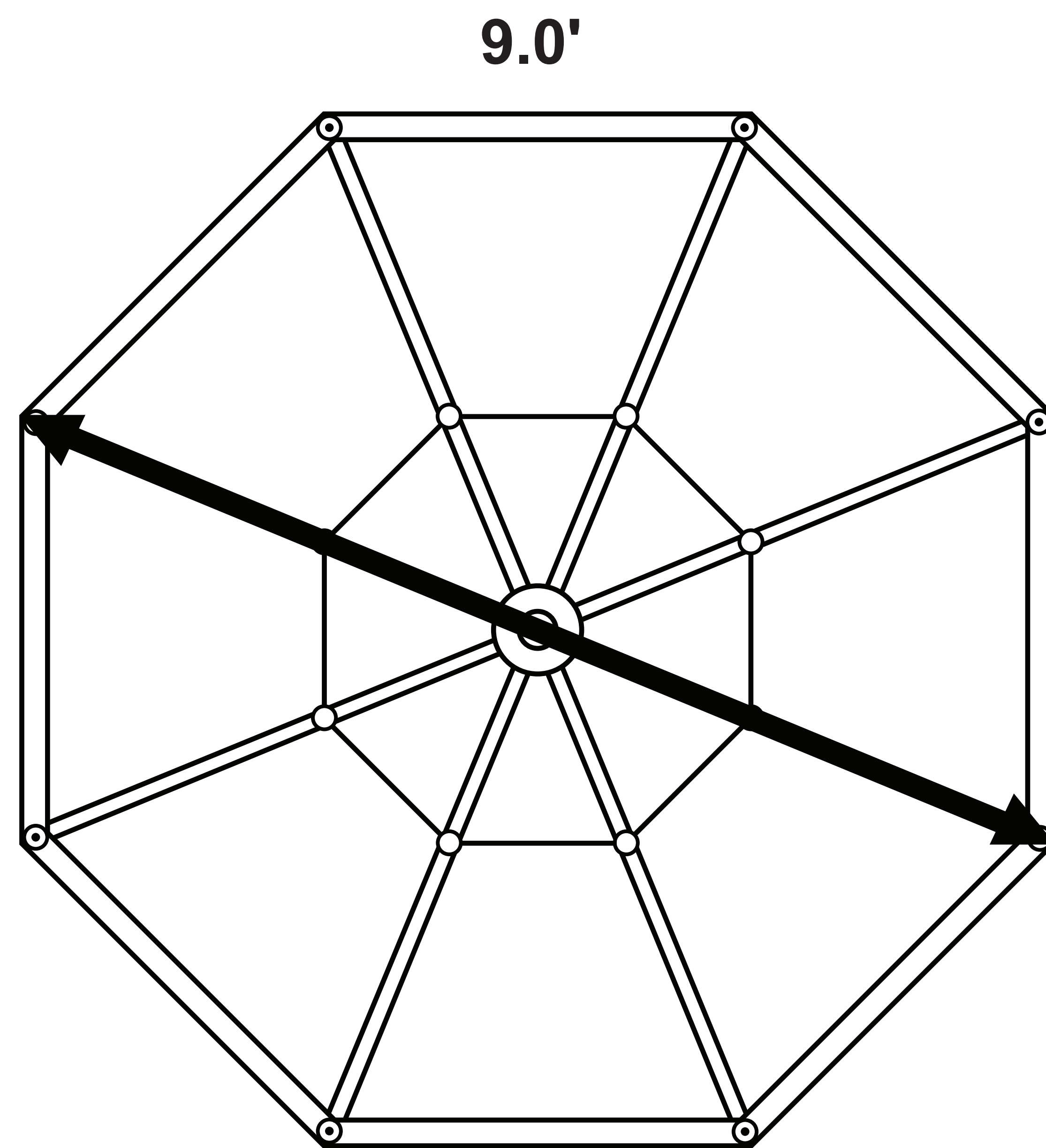

- **9' OCTAGON**
- **FIBERGLASS RIBS 3/4" DIAM**
- **ALUMINUM POLE 2" DIAM**

**FRONT ELEVATION**



**COMPONENTS**

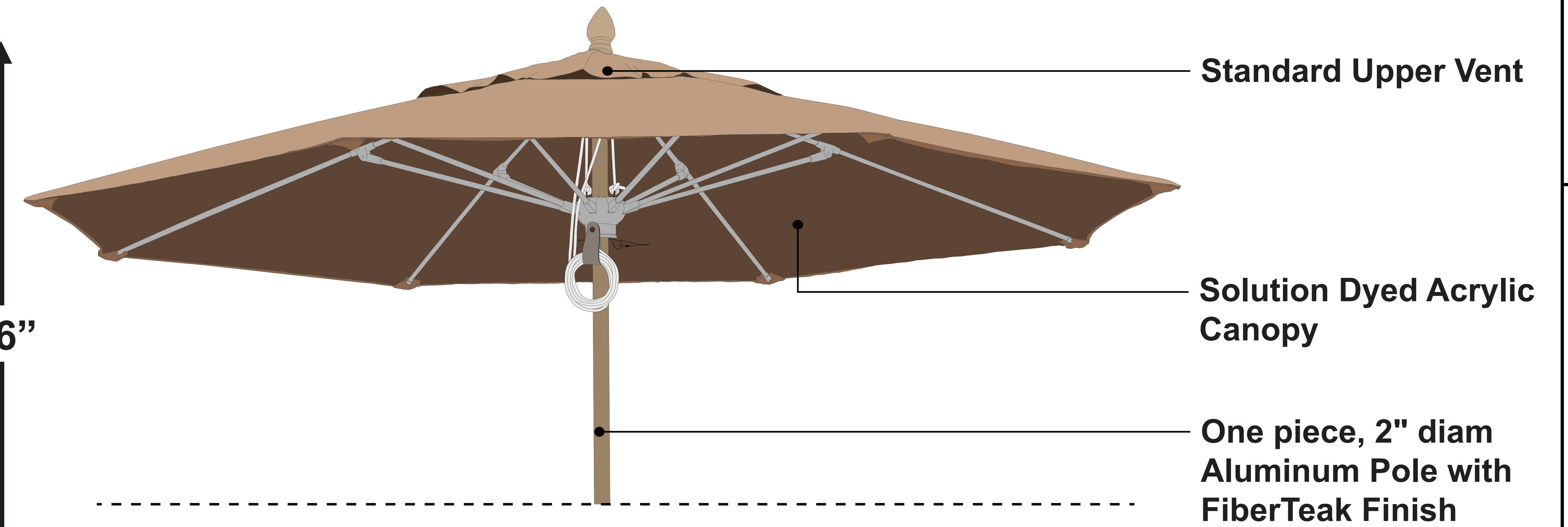

**A**



**DETAIL A**  
INTERNAL VIEW  
OF POLE CONSTRUCTION.

**B**

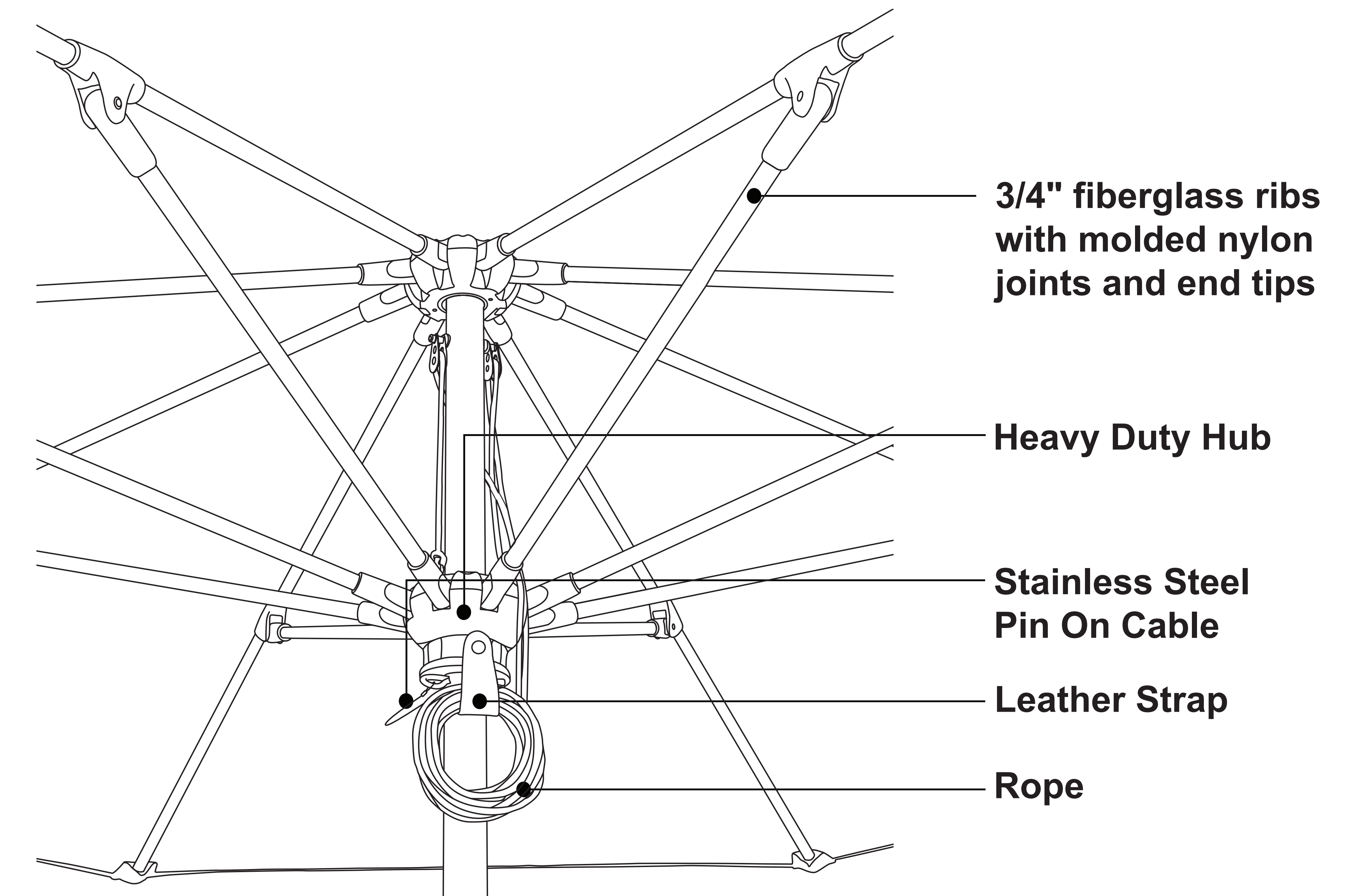

**DETAIL B**  
RIB, HUB AND PULLEY  
ASSEMBLY

**GENERAL NOTES:**

1. All Dimensions Are In Inches.
2. 93% Manufactured In The **USA**.

**Available Sizes**

9' oct with Push Up & Pin or Pulley & Pin Lift Height: 96" Weight: 36 lbs	11' oct with Pulley & Pin Lift Height: 102" Weight: 40 lbs	13' oct with Pulley & Pin Lift Height: 108" Weight: 58 lbs
---	--	--

<b>PRESTIGE COLLECTION</b>
<b>MODEL: AUGUSTA OCTAGON</b>
<b>DRAWING DATE: 2026</b>



**PLAN VIEW**

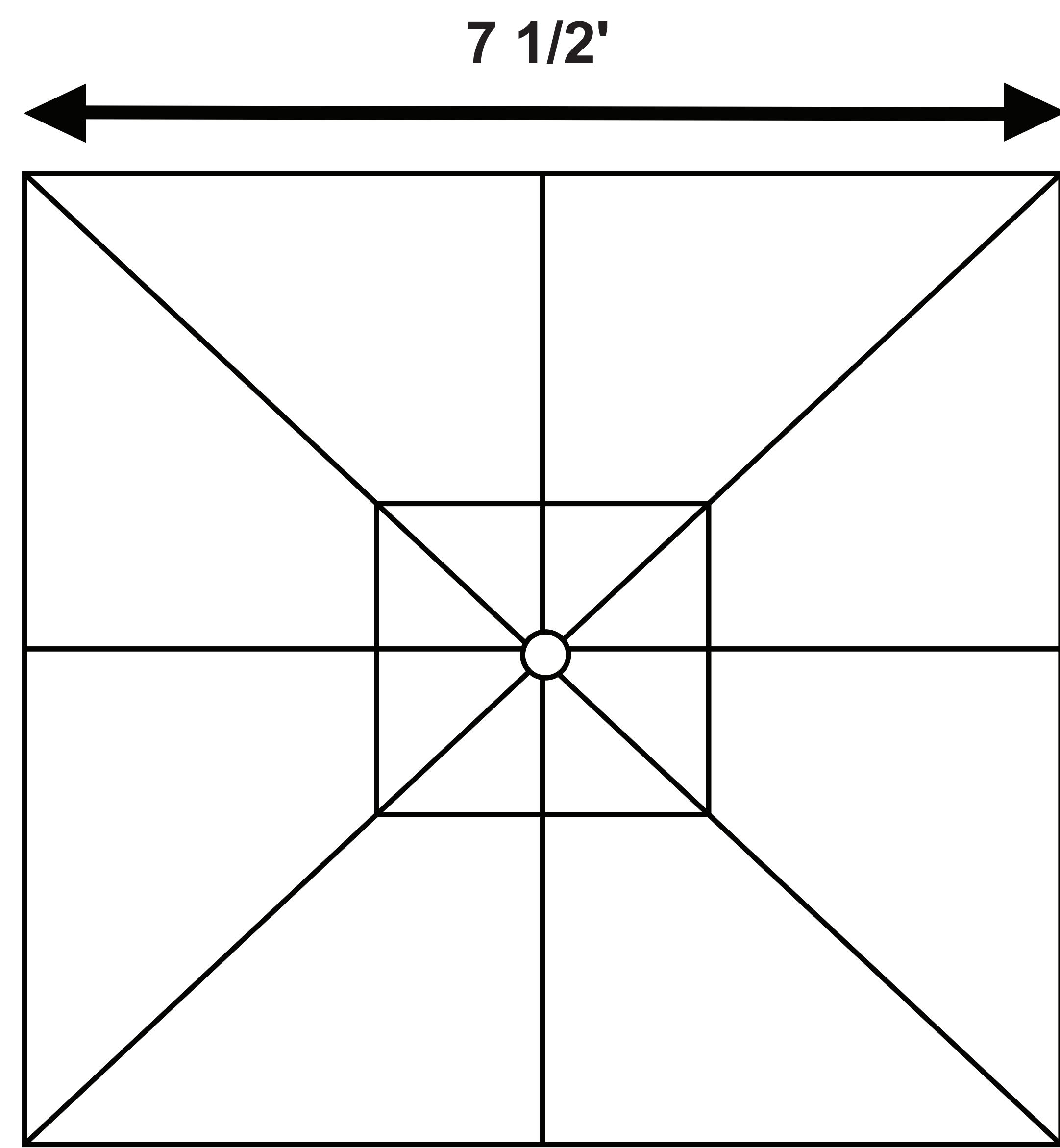

- 7 1/2' SQUARE
- FIBERGLASS RIBS 3/4" DIAM
- ALUMINUM POLE 2" DIAM

**FRONT ELEVATION**



**COMPONENTS**

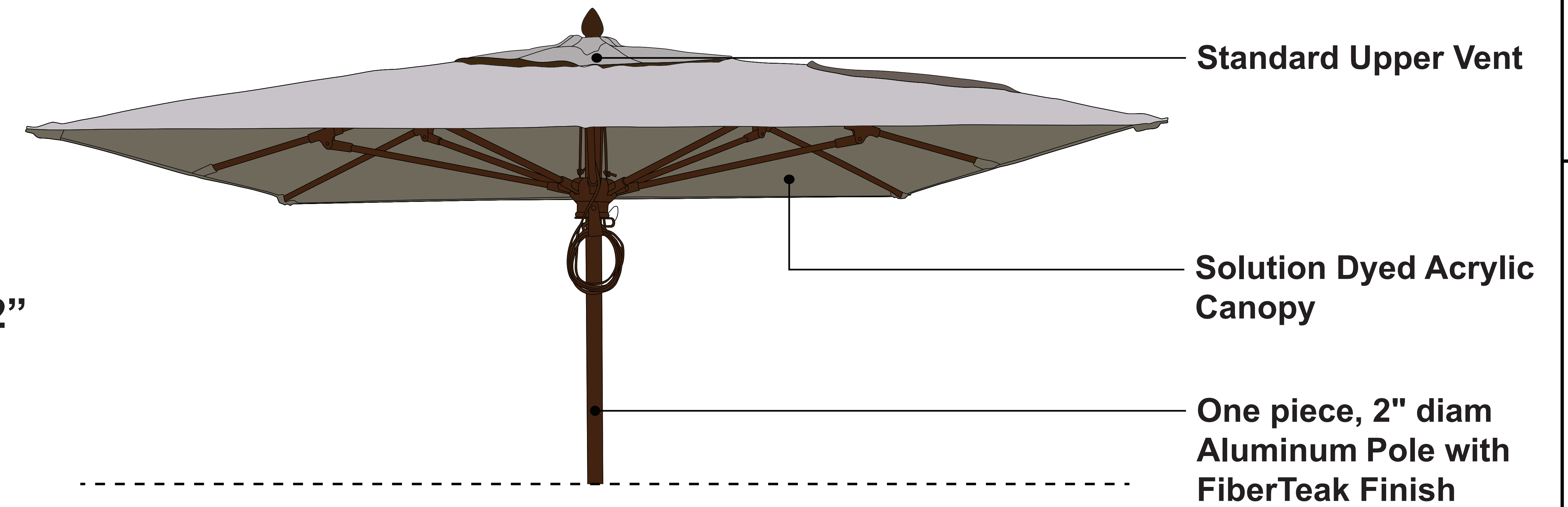

**A**

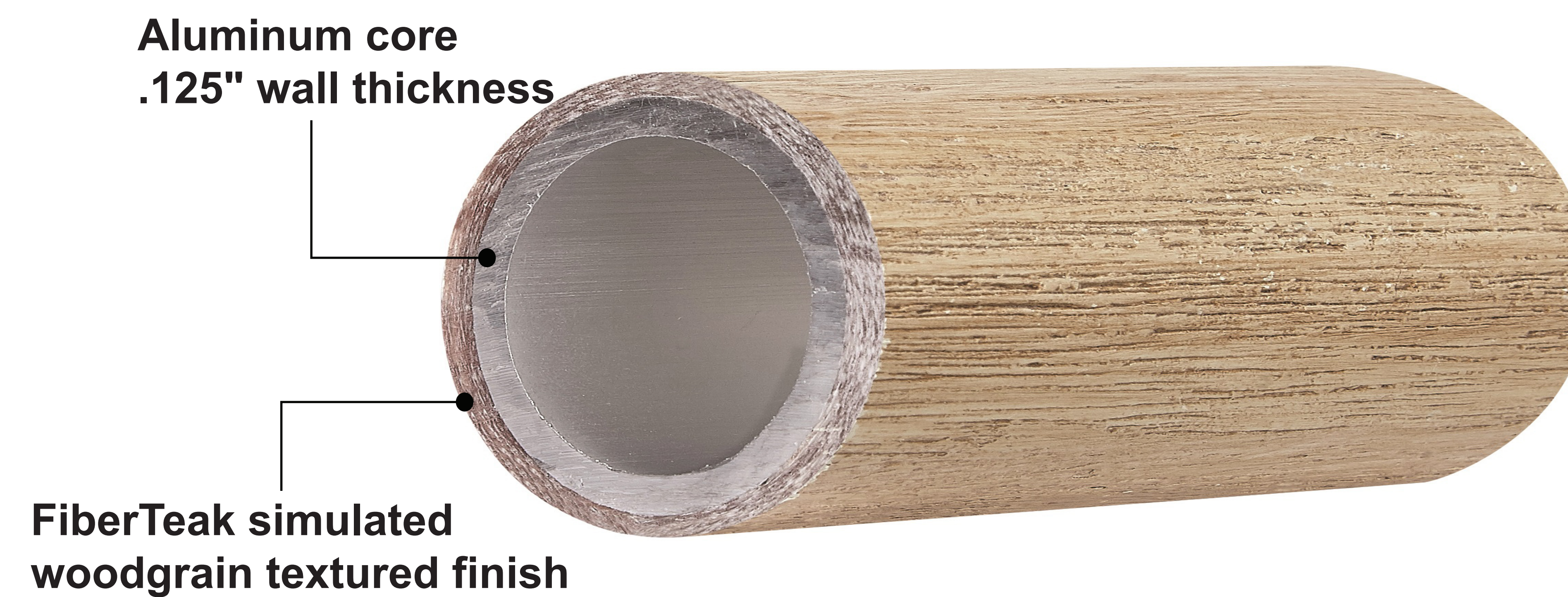

**DETAIL A**  
INTERNAL VIEW  
OF POLE CONSTRUCTION

**B**

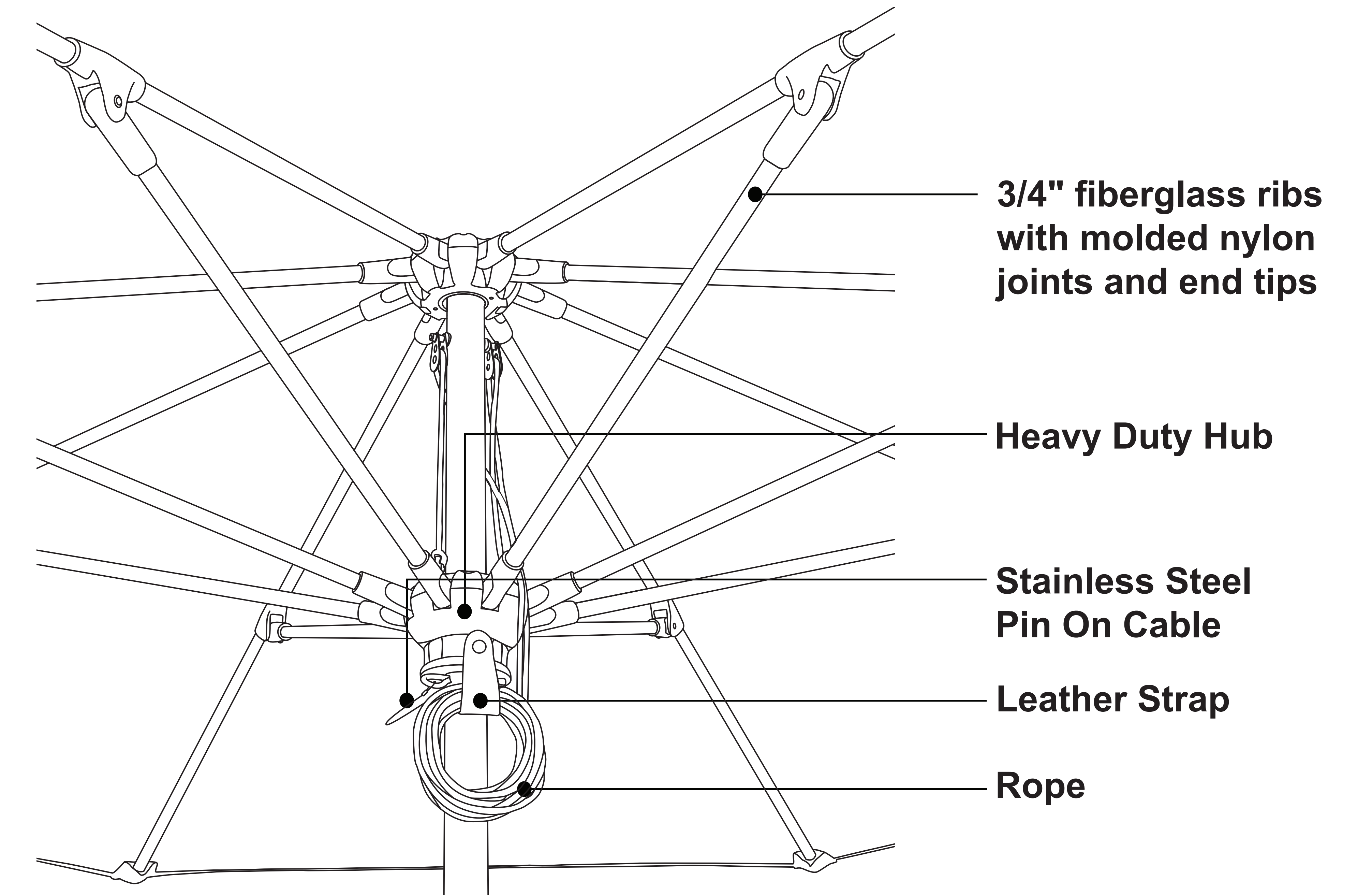

**DETAIL B**  
RIB, HUB AND PULLEY  
ASSEMBLY

**GENERAL NOTES:**

1. All Dimensions Are In Inches.
2. 93% Manufactured In The USA.

**Available Sizes**

6' sq with Push Up & Pin Lift Height: 96" Weight: 32 lbs	7 1/2' sq with Pulley & Pin Lift Height: 102" Weight: 34 lbs	10' sq with Pulley & Pin Lift Height: 108" Weight: 58 lbs
--	--	---

<b>PRESTIGE COLLECTION</b>
<b>MODEL: AUGUSTA SQUARE</b>
<b>DRAWING DATE: 2026</b>

