



# Fiberbuilt

## UMBRELLAS & CUSHIONS

FIBERBUILT UMBRELLAS & CUSHIONS

2201 W. ATLANTIC BLVD  
POMPANO BEACH, FL 33069

TOLL FREE: 1-866-667-8668

PHONE: (954) 484-9139

FAX: (954) 484-4654

www.fiberbuiltumbrellas.com

SELECT DESIRED SIZE & SHAPE:

7 1/2' OCT     9' OCT

SELECT DESIRED FINISH COLOR:

W - WHITE  
 CB - CHAMPAGNE BRONZE  
 BK - BLACK

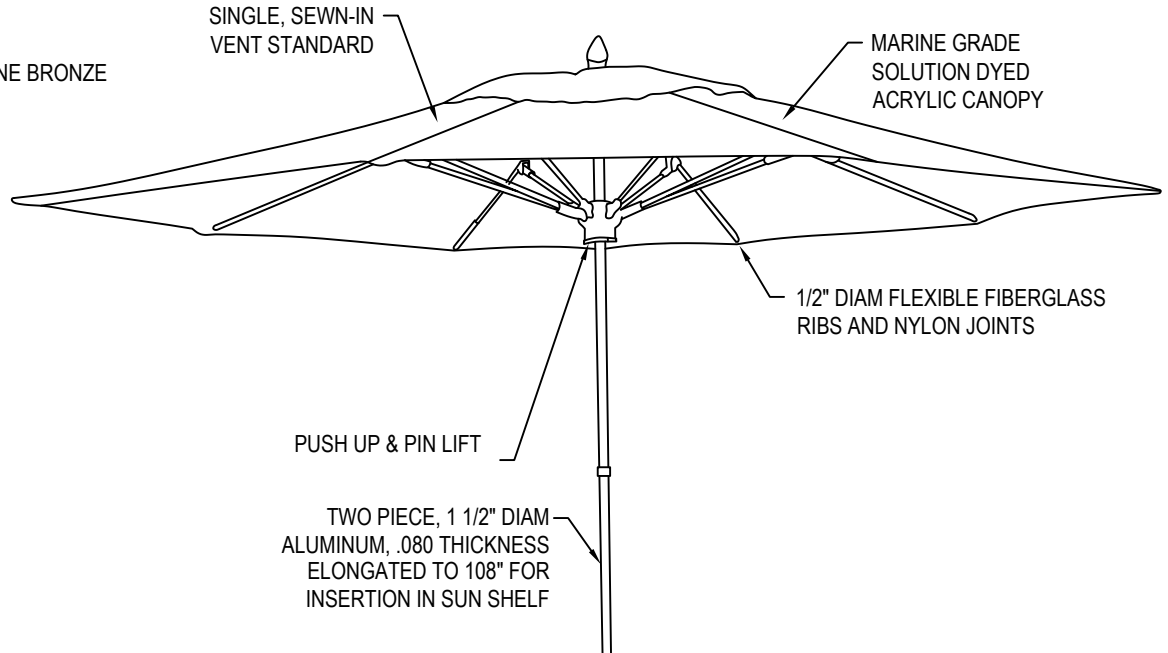

PERSPECTIVE

<b>SPECIFICATIONS</b>	<b>7 1/2' OCT</b>	<b>9' OCT</b>
<b>MODEL #:</b>	7IMPU	9IMPU
<b>FIBERGLASS RIBS:</b>	1/2" DIAM	1/2" DIAM
<b>LIFT:</b>	PUSH UP & PIN	PUSH UP & PIN
<b>HEIGHT:</b>	108"	108"
<b>WEIGHT:</b>	17 LBS	20 LBS

**MANUFACTURER NOTES:**

1. CUSTOM LOGO, CANOPY PATTERNS AND FABRIC OPTIONS ARE AVAILABLE. CONSULT YOUR REPRESENTATIVE, VISIT OUR WEBSITE OR CONTACT THE FACTORY FOR ADDITIONAL INFORMATION.
2. UMBRELLAS MUST BE SECURED IN PROPERLY FITTING IN-POOL SLEEVES. CONSULT YOUR CONTRACTOR.

**NOTES:**

1. INSTALLATION TO BE COMPLETED IN ACCORDANCE WITH MANUFACTURER'S SPECIFICATIONS.
2. DO NOT SCALE DRAWING.
3. THIS DRAWING IS INTENDED FOR USE BY ARCHITECTS, ENGINEERS, CONTRACTORS, CONSULTANTS AND DESIGN PROFESSIONALS FOR PLANNING PURPOSES ONLY. THIS DRAWING MAY NOT BE USED FOR CONSTRUCTION.
4. ALL INFORMATION CONTAINED HEREIN WAS CURRENT AT THE TIME OF DEVELOPMENT BUT MUST BE REVIEWED AND APPROVED BY THE PRODUCT MANUFACTURER TO BE CONSIDERED ACCURATE.
5. CONTRACTOR'S NOTE: FOR PRODUCT AND COMPANY INFORMATION VISIT [www.CADdetails.com/info](http://www.CADdetails.com/info) AND ENTER REFERENCE NUMBER 5294-019

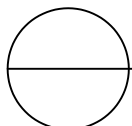

## IN-POOL UMBRELLA TWO PIECE POLE WITH PUSH UP & PIN LIFT

UMBRELLAS - IN-POOL COLLECTION